

Protective solutions

Applications

The PVD-150 exhaust blast valve is used as exhaust air valve of Civil Defence and Military shelters. The PVD-series exhaust blast valves are specially designed to be used in the exhaust systems of diesel engines and are suitable for other applications with hot and corrosive gases.

Specification

Manufacturer of PVD-150 exhaust blast valve is Temet, Helsinki Finland.

The PVD-150 exhaust blast valve comprises a special heat resistant steel pressure disk mounted on a stainless steel spindle within cast steel valve body and casing. The valve disk is held open by the gas flow and closes in response to the blast load. The valve is also available with spring-loaded pressure disk for applications in which the gas/air flow is not sufficient to keep the pressure disk in the open position during normal operation.

Design Criteria

The PVD-50 exhaust blast valve is made in accordance with specific provisions issued by the Finnish Ministry of Interior. The PVD-150 blast valve is type tested and approved for use by the Technical Research Centre of Finland / VTT Building Technology, an Independent Testing Authority mandated to perform type inspection for shelter equipment and systems by the Ministry of Interior. Type test reports as well as additional test data are available upon request.

Test and performance data

The valve is designed and tested to withstand multiple long duration (peak duration >60 ms) blast loads having peak reflected overpressure of 20 bar and short duration (positive phase duration <5.0 ms) blast load having peak reflected overpressure of 60 bar while retaining its full functional ability.

The valve is shock tested in directions of the three main axis with a mechanical shock of installation base having an acceleration of 80 g.

The valve is designed to function within operating temperature range of -20 ... +520 °C. The high temperature models of the PVD valves are designed to provide complete blast protection up to 650°C operation temperature.

The type test report

VTT type test report and additional test data is available upon request.

Other documents related to PVD-150 Exhaust Blast Valve:

- Installation Instruction
- Operation & Maintenance Instruction

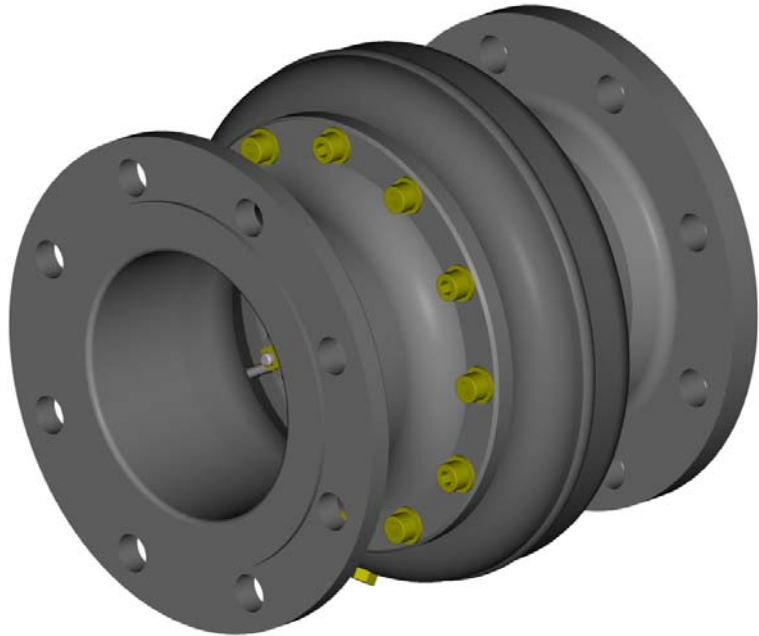

PVD-150 Exhaust Blast Valve

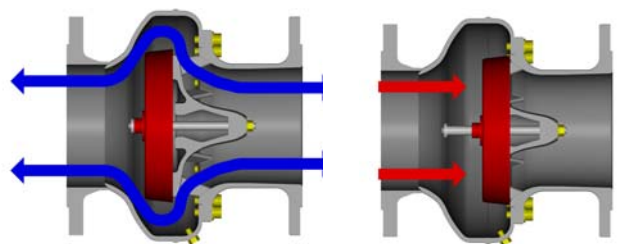

Normal operation
Valve is held open by
the gas flow

Blast pressure
from the outside
Valve closes

PVD-150 Exhaust Blast Valve
Operation Principle



PVD-150 Exhaust Blast Valve with PK150LPV500 wall sleeve

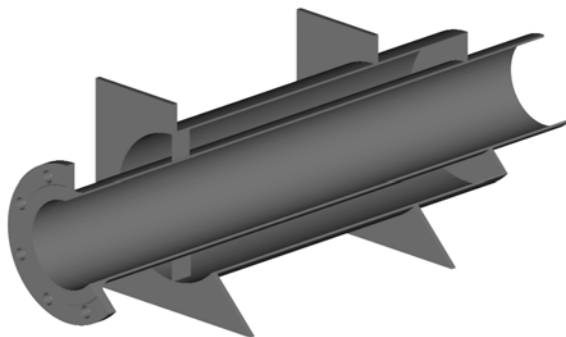

Temet LP-PP wall sleeves are made specially for the hot exhaust gases. The heat transfer to the walls is minimized with the unique wall sleeve construction. The high temperature wall sleeves LP-PP-HT are recommended for use with high temperature PVD valves.

PVD-150-BS is a complete fixing bolt set with sealant. PVD-150-BS-HT is a complete fixing bolt set with sealant for high temperature models.

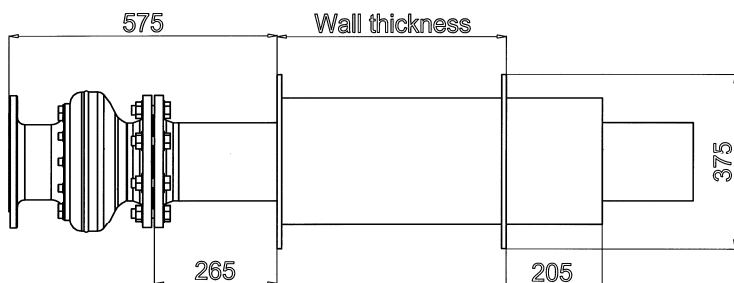

PVD-150 Exhaust Blast Valve dimensions

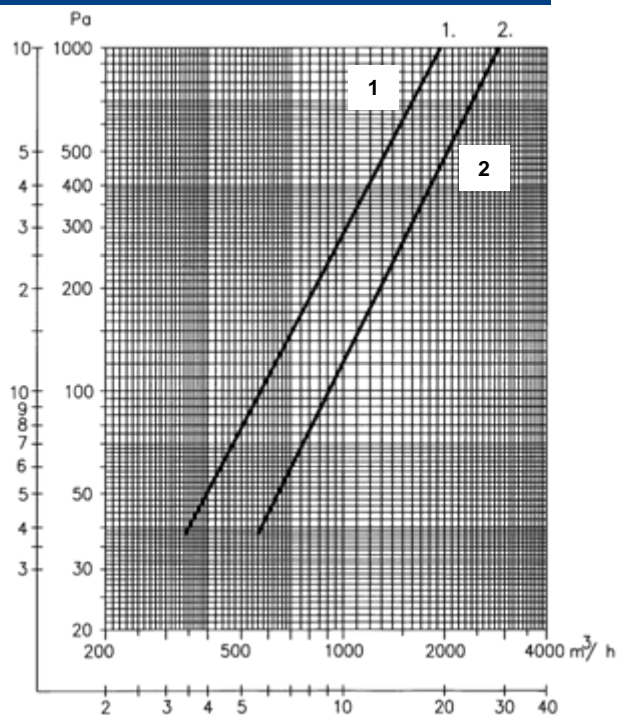

Graph 1. Air flow characteristics measured with air at 20 °C corresponding to air density of 1.20 kg/m³.

Graph 2. Gas flow characteristics measured with exhaust gas at 520 °C corresponding to gas density of 0.50 kg/m³.

Example for valve selection:

The shelter auxiliary power system has a diesel engine having a nominal exhaust gas flow of 2000 m³/h. The maximum recommended back pressure caused by blast valve is 500 Pa. The required Exhaust Blast Valve type is PVD-150 2000 m³/h at 450 Pa.

If the exhaust gas temperature has not been informed by generator manufacturer, the valve type can be selected depending on the distance of the valve from the diesel engine. For location less than 2 meters from the engine the high temperature model designed for 650°C operating temperature is recommended, for locations more than 2 meters the normal type of PVD-150 valve can be used.

Valve	Width x Height of wall sleeve (mm)	Min wall thickness (mm)	Weight of valve (kg)	Weight of wall sleeve (kg) for wall thickness 600 mm	Total weight (kg)	Air Flow at 100 Pa (m ³ /h)	Air Flow at 200 Pa (m ³ /h)	Air Flow at 300 Pa (m ³ /h)	Air Flow at 500 Pa (m ³ /h)
PVD-50	240x240	300	8	22	30	160	220	260	340
PVD-100	300x300	300	20	40	60	280	420	540	680
PVD-150	375x375	300	35	58	93	900	1300	1550	2100
PVD-250	450x450	300	95	100	195	3240	4320	5940	7200

Design - Production – Installation – Maintenance - Consultation